



Angle valves. By SCHELL.

SCHELL.

Angle valves of the highest quality.



Plant 1
Production with administration building and training centre



Plant 2
Production with logistics centre



**Choose the Original
Choose Success!**

SCHELL supports original technology and opposes the infringement of intellectual property rights.



GL Systems Certification

kiwa

Europe's number one.

As a leading angle valve specialist, SCHELL constantly brings new innovations onto the market or adapts its products according to changing requirements.

SCHELL sanitary fittings are developed under the concept of functional aesthetics. On one hand, this results in excellent workmanship. However, on the other hand it also ensures an individual, integrated design concept that goes beyond the individual product itself. Whether design angle valves,

draw-off taps, shower fittings or WC and urinal flush systems – the classically designed sanitary fittings from SCHELL can be easily combined and have received numerous awards.

Why not find out what is actually in our products. If you have any queries regarding our angle valves, simply give us a call. We are more than happy to help.

Telephone +49 (0) 27 61 8 92-0
www.schell.eu

List of contents

SCHELL inside	Page 4
WELL	Page 5
Angle valve functions	Page 6
Drinking water safety	Page 9
Filter technology	Page 10
Angle valve thermostat	Page 12
QUAD and STILE design angle valves	Page 14
EDITION design angle valves	Page 16
PURIS, CLASSIC, RONDO, WING, 4WING, PINT and SONO design angle valves	Page 18
COMFORT ECO regulating angle valve, flow regulator	Page 20
ASAG easy, roughening	Page 21
The angle valve specialist. Selection.	Page 22
References	Page 24



EDITION design angle valve set

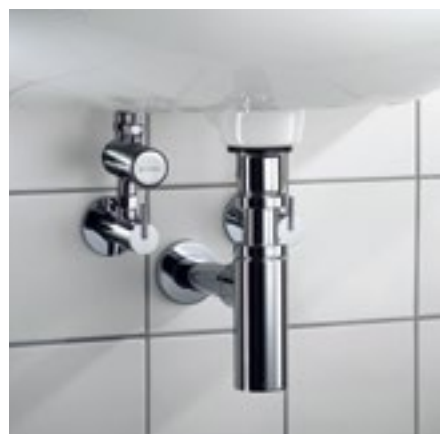

Angle valve thermostat

SCHELL inside.

System solutions from the specialist.

SCHELL responds with robust, hygienic and resource-efficient solutions wherever they are needed, such as in public, semi-public and commercial sanitary rooms that experience high numbers of users; in schools, hotels, stadiums or motorway service stations. And maybe soon in your own property.

Among others, our solutions can be found in the following locations all over the world:

- Schools
- Nurseries
- Hotels
- Gastronomy
- Hospitals
- Residential nursing homes
- Industry
- Administrative buildings
- Airports
- Railway stations
- Motorway service stations
- Leisure facilities
- Sports facilities
- Swimming pools

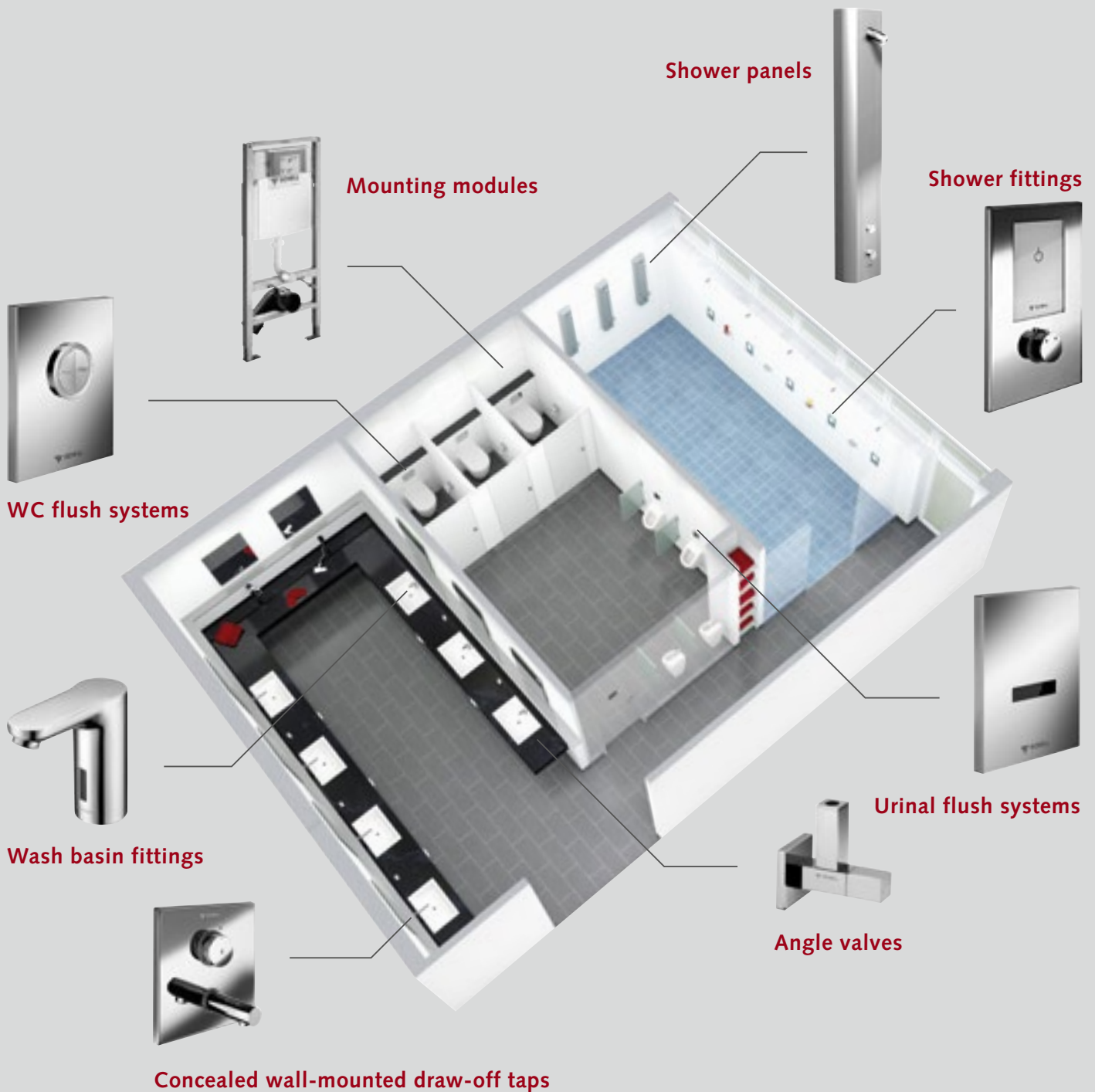

SCHELL is synonymous with sustainable solutions.
And this is now official too.

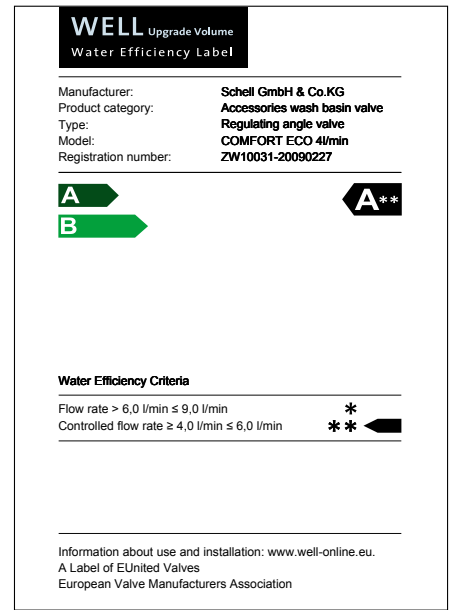

WELL, the new efficiency label of the European valve industry.

With its intelligent valve technologies, SCHELL has proved for many years how to achieve sustainable solutions with regard to water consumption, hygiene and product quality. And this is now official too.

In order to provide planners and developers with a neutral orientation aid, the European valve industry (EUnited Valves) has now developed a new, informative and most importantly standardised product classification label that indicates the saving potential of a fitting in a bold and striking manner. The basis for the qualification of each fitting is compliance with applicable European norms and standards. These are tested and approved by an accredited, independent test institute (EN ISO/ICE 17025) as part of the type examination test. This ensures that only mate-

rials are used that are not hazardous in terms of hygiene and whose functional safety has been proven in an endurance test. Compliance with drinking water hygiene remains the utmost priority here.

With the first WELL-classified fittings, SCHELL documents its high aspirations on quality, and also proves that sustainability and minimal water consumption on fittings do not come into conflict with drinking water hygiene directives.

SCHELL is a member of the initiative



More information can be found at:
www.blue-responsibility.com



SCHELL achieves the highest international water-saving assessments



SCHELL is a member of the European fittings association, EUnited Valves

Angle valve functions. By SCHELL.

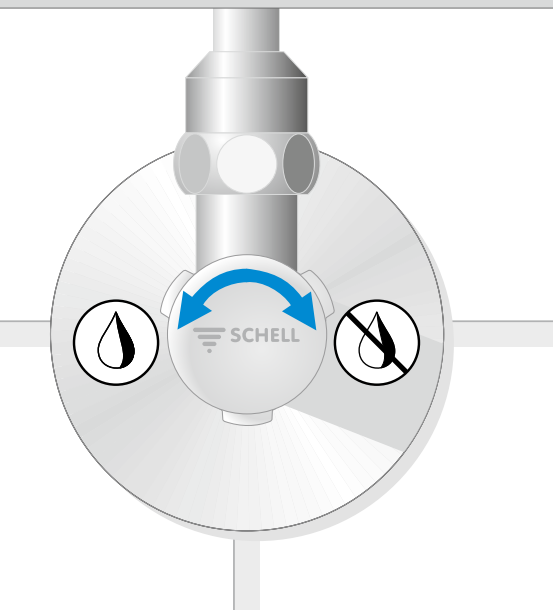

Shut off

Shut off (for repairs, maintenance, changing fittings).

It's child's play – simply turn the operating handle clockwise to shut off the angle valve. The water flow is stopped and wash basin fittings can now be easily dismantled, serviced or repaired. A grease chamber ensures that the valve is always easy to open, regulate and close as it protects the brass spindle against lime-scale deposits.

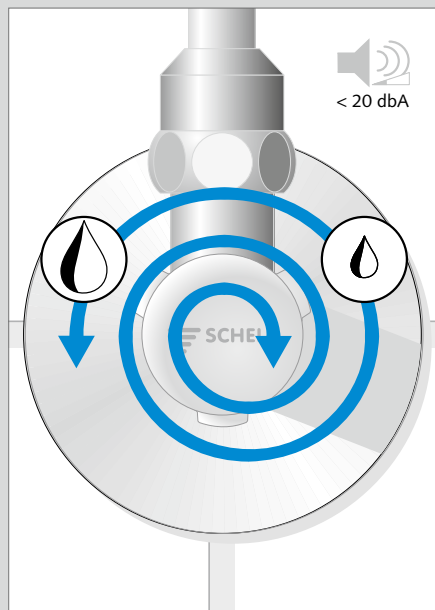

Regulate

Regulating (flow compensation with different pressures).

In contrast to shutoff ball valves, SCHELL regulating angle valves can regulate flow volumes of cold and hot water as well as compensate for different pipe pressures. SCHELL regulating angle valves have a sound level of < 20 dB (A) with a flow pressure of 3 bar over their full adjustment range. The noise level remains pleasantly low at whatever setting.

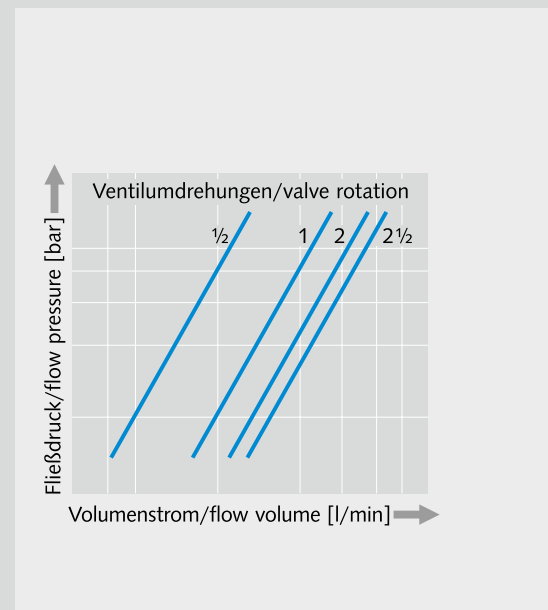

Save water

Water consumption can be reduced by up to 40 % without any loss of convenience using an optional, regulated angle valve.

This not only creates savings in relation to hot water, but also reduces harmful CO₂ emissions.

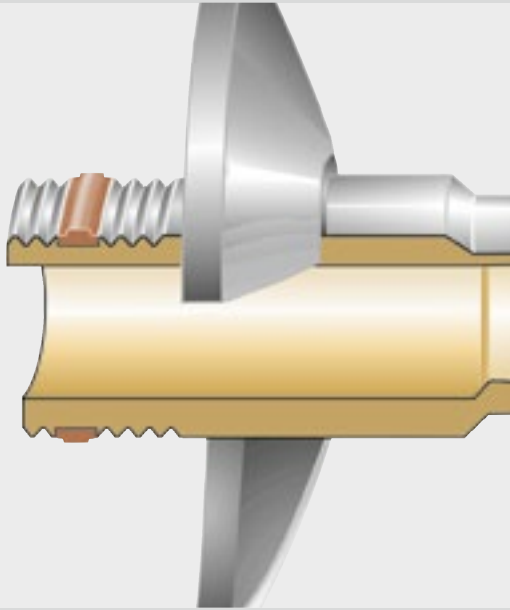

Seal

Angle valves with a self-sealing connecting thread (ASAG easy) make installation much easier. You no longer need to seal the connection with hemp or Teflon tape. Simply screw the angle valve on over the ASAG easy ring until it reaches the end of the thread – the connection will remain tight even after adjustment through reverse rotation.

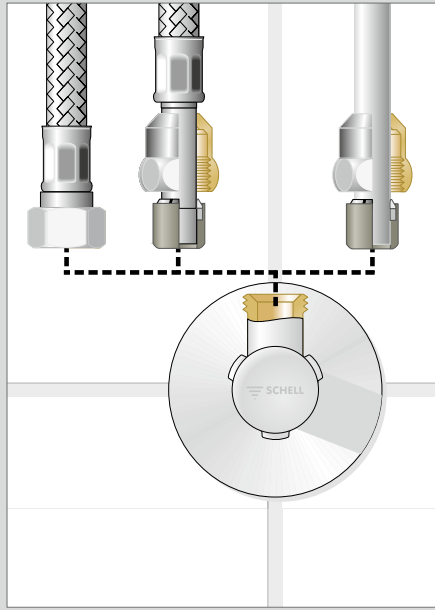

Replace

Detachable connections to fittings (easy to replace). The special cone compression connection enables quick and easy connection between the angle valve and copper pipes or flexible hoses. On angle valves without a compression connection, the angle valve is connected to flexible hoses using the retaining nuts and gasket.

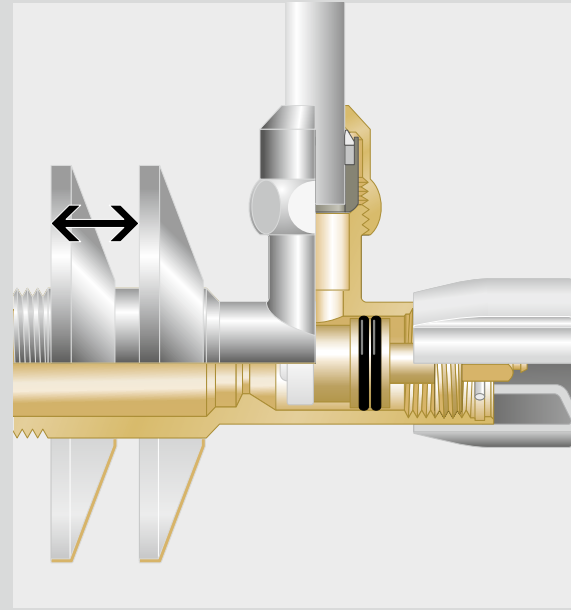

Compensate

Compensating connection tolerances (vertical compensation, push-on rosette).

The push rod on the angle valve shaft and the push-on rosette compensate for any potential installation errors of up to 18 mm. SCHELL not only offers the standard push-on rosette with Ø 54 mm, but also larger rosettes with Ø 65 mm to compensate for less than perfect tiling.

Quality features. By SCHELL.

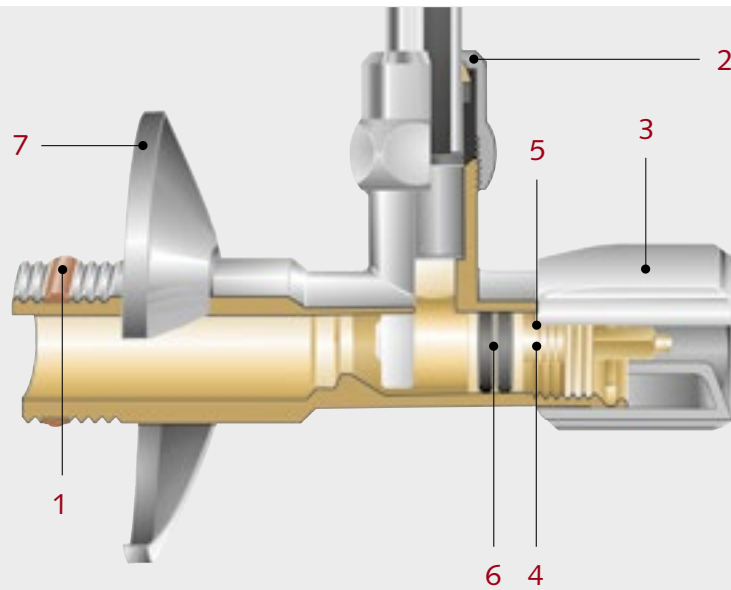

Advantages

Non-compromising quality

- 1 Faster assembly thanks to self-sealing connecting thread (ASAG easy)
- 2 Secure connection via the 3-part brass cone compression connection with length compensation
- 3 SCHELL COMFORT handle
- 4 Water-protected brass spindles that are always easy to operate
- 5 Grease chamber for ensuring long-lasting ease of movement
- 6 Maintenance-free, double O-ring seal
- 7 Increased flexibility with push-on rosette – 18 mm push distance

Reliable technology for safe drinking water.

By SCHELL.



High-quality materials



Angle valve with filter



SCHELL sampling angle valve

Materials made for drinking water.

SCHELL fittings comply with the DIN 50930/6 standard. DIN 50930/6 states the conditions (alloy components) needed for brass to meet the requirements of the Drinking Water Ordinance (TrinkwV).

Protection against contamination in drinking water.

Dirt particles and limescale deposits are continually flushed through the pipe network and mixed with drinking water. They are not only perceived as undesirable and unhygienic, they can also cause major damage to draw-off taps. This is why it makes sense to use SCHELL filter angle valves. The filter seated inside the angle valve catches harmful particles; it can then be easily released using a coin or screwdriver and washed clean under running water.

In the amended Drinking Water Ordinance from 2011 (§14, paragraph 3), the microbiological testing of legionella is specified for buildings with large-scale plants used for heating drinking water for public or commercial drinking water installations.

The SCHELL sampling angle valve meets the requirements for systematic testing within sanitary rooms. As water flows constantly through the angle valve to the draw-off tap, a statement can be made regarding the water quality within the drinking water installation (systematic testing).

Filter technology. By SCHELL.



Regulating angle valve with microfilter



Regulating angle valve with microfilter
and backflow preventer

Tried-and-tested filter technology.

The tried-and-tested brass spindle (technology with O-ring seal which is used in millions of SCHELL angle valves with filter) is put to use here. It guarantees ease of movement even after many years of operation.

Maintenance-free.

The grease chamber and double O-ring seal protect the brass spindle against calcareous water. This is how SCHELL guarantees smooth-running, maintenance-free fittings with a long service life.



Consistently the temperature you want, with scald protection.

Safety, quality and design. **Angle valve thermostat. By SCHELL.**





Angle valve thermostat

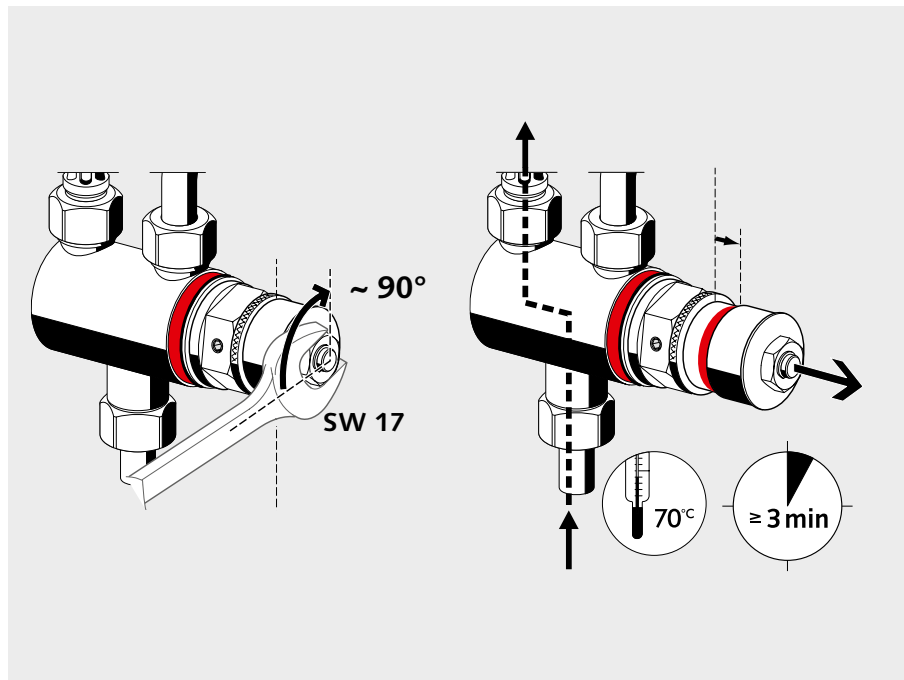

Implementation of thermal disinfection

The angle valve thermostat from SCHELL offers a reliable, easy to install and visually attractive solution for scald protection. The thermostat is installed above the angle valve for the hot water pipe with a connection pipe to the cold water line; it guarantees that the draw-off temperature remains constant, e.g. at 38 °C – irrespective of pressure fluctuations. The desired temperature can also be altered to suit your needs.

Advantages and areas of application:

- Limits maximum draw-off temperature
- Individual temperature adjustment
- Option of thermostatic disinfection (protection against legionella)
- Easy installation
- Also ideal for retrofitting
- Typical areas of use: Schools, nurseries, hospitals, retirement homes, hotels etc.

Item no. 09 406 06 99



QUAD – the highlight under the wash basin from SCHELL. Wherever you value a perfect, stylish ambience.

Design developments under the wash basin.

By SCHELL.



QUAD design angle valve with chrome handle



STILE design angle valve with concealed valve actuation

QUAD design angle valves.

The strictly cubic design of the QUAD angle valve reflects current trends in architecture, and is also available with a pure chrome handle.

STILE design angle valve.

STILE combines simple elegance and tried-and-tested technology. The design regulating angle valve is comprised of a polished brass body, high-tensile SCHELL brass cone compression connection with length compensation and concealed valve actuation underneath the cover cap.

Accents in any sanitary room. By SCHELL.



EDITION design angle valve



EDITION design regulating angle valve set

EDITION regulating angle valve series.

This award-winning product (iF design award 2003 and DESIGN PLUS award) was created by sieger design, and is an integral part of the attractive bathroom as the EDITION set. The regulating angle valves and design siphon satisfy high design standards underneath the wash basin.



reddot design award
winner 2004

DESIGN PLUS



iF
award
2003

Technology used to be something to hide, but now it has a functional beauty that's worth showing off.



Solutions for all styles. By SCHELL.



PURIS
design angle valve



CLASSIC
regulating angle valve



RONDO
regulating angle valve

PURIS.

The handle design is tailored to current trends in the draw-off tap segment. PURIS supplements the draw-off tap of the same name with its minimalist design. The EDITION siphon rounds off the range perfectly.

CLASSIC and RONDO.

These two angle valve series represent the core classic styles of the SCHELL product range. The operating handles are an integral part of the design. CLASSIC and RONDO fit harmoniously into the ambience of classic sanitary rooms.



WING
design regulating angle valve



4WING
design regulating angle valve



PINT
design regulating angle valve



SONO
design regulating angle valve

WING and 4WING.

More design under the wash basin. SCHELL has added two more attractive models to its range of design regulating angle valves: WING and 4WING. The inner values of the two newcomers also speak for themselves: DIN EN brass is used as the valve body material. Both regulating angle valves also have a high-tensile SCHELL brass cone compression connection with length compensation and noise class I.

PINT and SONO.

Enter the SCHELL design class. SCHELL offer two new products, PINT and SONO, as basic solutions in design-oriented regulating angle valves. The attractive shape and high-tensile SCHELL brass cone compression connection with length compensation and noise class I speak for themselves.



COMFORT ECO.

DIN regulating angle valve with integral flow regulator.



COMFORT ECO is the ideal component for upgrading existing systems.

Saves on water consumption – but not on WELL stars.

Regulating angle valves significantly affect the water consumption on draw-off taps. Get the right product and instantly the consumption costs can be clearly cut by simple means; just like the new COMFORT ECO DIN regulating angle valve in three different flow rate classes. The benefit: less water consumption and two stars as a WELL upgrade. The other benefits of COMFORT ECO: high-tensile SCHELL brass

cone compression connection with length compensation, self-sealing connecting thread (ASAG) and noise class I.

COMFORT ECO

DIN regulating angle valve with integral flow regulator and push-on rosette Ø 54 mm

- Design with flow rate: 9 l/min, item no. 04 951 06 99
- Design with flow rate: 6 l/min, item no. 04 952 06 99

Integral flow regulator for angle valves. By SCHELL.



The flow regulator is the ideal component for upgrading existing systems.

Small component, great effect.

Those who would like to reduce water consumption with little means, will in future be able to use the new pressure-independent flow restrictors from SCHELL. These are available in three different flow rate classes and in a DIN EN brass casing including seal. By the way, there are two WELL "upgrade" stars for using flow regulators.

SCHELL flow regulator, for DN 10 angle valves

- Design with flow rate: 9 l/min, item no. 06 552 06 99
- Design with flow rate: 6 l/min, item no. 06 553 06 99
- Design with flow rate: 4 l/min, item no. 06 554 06 99

By upgrading a flow regulator ($\leq 6,0$ l/min), two more stars can be achieved.



One-star single lever tap 12 l/min

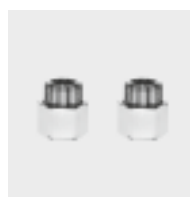

Two-star flow regulator

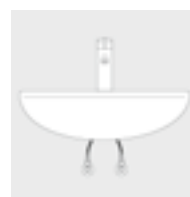

Three-star wash basin solution

ASAG easy. For regulating angle valves.

Installation is even easier, safer, quicker, and hygienic.

SHELL has further developed the ASAG (valve with self-sealing connecting thread). With ASAG easy, installation will not only be even easier and quicker in the future – with the seal of the same, reliable quality. ASAG easy also fulfils the requirements for hemp-free and hygienic installation technology. In order to enable the connecting thread to be screwed in with less effort, the form of the PTFE ASAG

ring in the ASAG easy has been optimised. The screwed-in fitting can also be aligned without any problems. By the way: the new ASAG easy is patented and is therefore only available at SHELL.



Create added value with innovative detailed solutions – SHELL has achieved this with ASAG easy.

Roughening. Easier mounting for all non self-sealing fittings.

Connecting threads will never have to be roughened with a saw blade at the construction site again – this is promised by the new thread roughening from SHELL. The roughening depth has been selected by the SHELL specialists to ensure that the hemp remains safely in the

thread, thereby always guaranteeing a professional threaded connection. This incidentally does not affect the accuracy of thread dimensions.



Mounting made easy: the roughened surfaces allow the threads of the fittings to be sealed quickly and reliably.

The angle valve specialist. Selection.

ANGLE VALVES



SCHELL COMFORT regulating angle valve

- COMFORT handle
- Long push rod
- Push-on rosette Ø 54 mm

Item no. 04 917 06 99

G 1/2 x G 3/8

DESIGN ANGLE VALVES



SCHELL CLASSIC regulating angle valve

- Long push rod
- Push-on rosette Ø 65 mm
- With ASAG easy

Item no. 05 172 06 99



SCHELL COMFORT regulating angle valve

- COMFORT handle
- Long push rod
- Push-on rosette Ø 54 mm

Item no. 05 217 06 99

G 1/2 x G 1/2



SCHELL RONDO regulating angle valve

- Long push rod
- Push-on rosette Ø 65 mm
- With ASAG easy

Item no. 05 152 06 99



SCHELL QUICK COMFORT regulating angle valve

- Push-fit technology
- Non-detachable, pull-proof and twist-proof installation into the QUICK Adapter

Item no. 05 304 06 99



SCHELL PURIS design angle valve

- Long push rod
- All-metal construction
- Sanitary grease chamber head part

Item no. 05 311 06 99



SCHELL regulating angle valve with normal filter

- Long push rod
- Backflow preventer (BP)
- With ASAG easy

Item no. 04 949 06 99

G 1/2 x G 3/8

Item no. 04 948 06 99

G 1/2 x G 1/2



SCHELL EDITION design angle valve

- Design: sieger design
- With ASAG easy
- Grease chamber spindle

Item no. 05 320 06 99



SCHELL COMFORT angle valve

- With sanitary head part
- COMFORT handle

Item no. 09 656 06 99

DESIGN ANGLE VALVES



- SCHELL QUAD design angle valve**
- Solid operating handle made of chrome
 - High-tensile cone compression connection with length compensation

Item no. 05 362 06 99

DESIGN ANGLE VALVES/VARIATIONS



- SCHELL STILE design angle valve**
- Polished brass body with push rod and push-on rosette Ø 60 mm
 - High-tensile brass cone compression connection with length compensation

Item no. 05 376 06 99
Item no. 05 377 06 99

G 1/2 x G 3/8
G 1/2 x G 1/2



- SCHELL EDITION design angle valve set**
- Design: sieger design
 - With ASAG easy
 - Connection set for wash basins

Item no. 05 321 06 99



- SCHELL WING design angle valve**
- Polished brass body with push rod and push-on rosette Ø 60 mm
 - High-tensile brass cone compression connection with length compensation

Item no. 05 392 06 99
Item no. 05 398 06 99

G 1/2 x G 3/8
G 1/2 x G 1/2



- SCHELL QUAD design siphon**
- Polished brass casing and pipes
 - Brass rosette with sliding ring

Item no. 01 505 06 99



- SCHELL 4WING design angle valve**
- Polished brass body with push rod and push-on rosette Ø 60 mm
 - High-tensile brass cone compression connection with length compensation

Item no. 05 393 06 99
Item no. 05 399 06 99

G 1/2 x G 3/8
G 1/2 x G 1/2



- SCHELL PINT design angle valve**
- Long push rod, push-on rosette Ø 54 mm
 - High-tensile SCHELL brass cone compression connection with length compensation

Item no. 05 390 06 99
Item no. 05 396 06 99

G 1/2 x G 3/8
G 1/2 x G 1/2



- SCHELL SONO design angle valve**
- Long push rod, push-on rosette Ø 54 mm
 - High-tensile SCHELL brass cone compression connection with length compensation

Item no. 05 391 06 99
Item no. 05 397 06 99

G 1/2 x G 3/8
G 1/2 x G 1/2



1 2



3 4

SCHELL – found everywhere where architects, planners and plumbers rely on non-compromising quality.



5 6



7 8



Photo: DMG/Christoph Münch

Large-scale renowned companies across the world trust in SCHELL when refitting their sanitary facilities. This is where the shared demand for design and quality in the details becomes apparent. SCHELL fittings are also used efficiently for redeveloping properties. Here are a few examples.

- 1 Ritter Sport Museum, Waldenbuch
- 2 Castle arcades, Braunschweig
- 3 Leisure pool, Schorndorf
- 4 Köln-Düsseldorfer, Deutsche Rheinschiffahrt Aktiengesellschaft
- 5 Sheraton Carlton, Nuremberg
- 6 Slavia Stadium, Prague
- 7 Burj Khalifa Complex, Dubai
- 8 Volkswagen AG, Dresden

Additional references can be found at www.schell.eu



SCHELL GmbH & Co. KG
Fittings Technology
Raiffeisenstrasse 31
57462 Olpe
Germany
Tel. +49 2761 892-0
Fax +49 2761 892-199
info@schell.eu
www.schell.eu

